

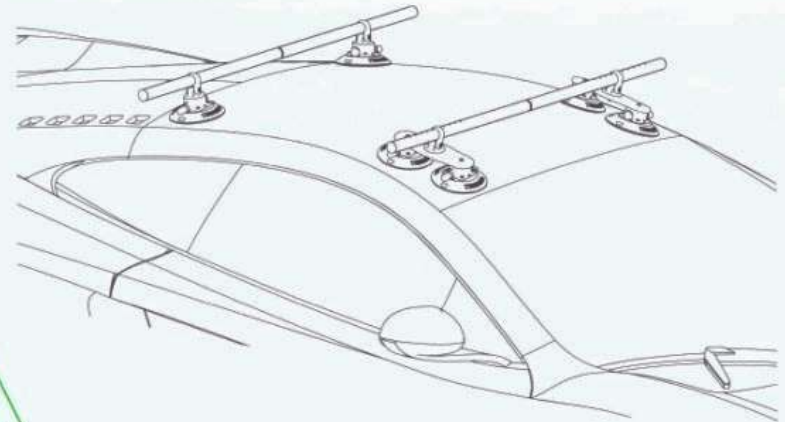

Owner's Manual

Multiple Crossbar Racks







IMPORTANT INSTRUCTIONS
Read This Before Using TreeFrog Products

WARNING:

Crossbar roof rack falling in the road can cause serious accidents resulting in bodily injury—do not use rack on any vehicle on which it can not be properly mounted as described in this instruction manual.

- All the TreeFrog vacuum mounts must be fully mounted completely to the metal, glass, or fiberglass surface - never attached to rubber or plastic moldings.
- Only the TreeFrog rubber vacuum mounts should be attached to the vehicle. Never use the rack on trailers or on the front of vehicles.
- Never carry more weight on the rack than the rack's maximum loading capacity.
- Drive conservatively, especially over bumps. Never use off road.
- Do not use if any part of the rack is damaged, worn, or missing. Contact to www.treefrog racks.com for replacement parts.

Load Limited Models	 DO NOT EXCEED RACK WEIGHT LIMITS!
 Multiple Crossbar Racks MXR0001S(B)	 40kg (88 lbs)
 Multiple Roundbar Racks MXR0001F	 40kg (88 lbs)

Safety first

- Clean the car mounting surface with the TreeFrog rag and the rubber vacuum pads with clean water before mounting the rack to the vehicle.
- Make sure that the rack's rubber vacuum pads are fully mounted to the surface, and all the vacuum pumps fully seated.
- Check the vacuum pump white indicator band during use.
- After you mounted your rack on your vehicle, and less than 3 hours later the sealing is not holding vacuum and the white safety indicator band is becoming visible, do not use the rack. Do the maintenance and test the bike rack for 24 hours before using it again!
- Lube the vacuum pumps regularly.
- Do not use if the indicator band is exposed on any of your pumps.
- Do not exceed the posted speed limit. Speed limits must under no circumstances exceed 130 km/h. Do not drive over speed bumps faster than 25 km/h.
- Regularly inspect screws, nuts and bolts after every couple of use and retighten if necessary.
- To ride front to back on the vehicle, not side to side.
- Test security by pushing and pulling on carriers.
- Always mount the front crossbar with 2-2 TreeFrog vacuum cups at both ends, at front of the roof, with placing and angle the 2 vacuum cups close to the edge of the roof, where the roof has more internal support. Then place the rear crossbar with 1-1 TreeFrog vacuum cup at both end at the back. Please place the rear crossbar vacuum cups close to the edge of the roof, to have more internal support.
- TreeFrog rack system allows you to attach the rack to the sunroof, but once the rack being installed, the sunroof must not be opened.
- TreeFrog crossbar racks maximum load is 40kg, but some cases the roof cannot support that much weight!
- Only the TreeFrog rubber vacuum pads should contact the vehicle.

CAUTION:

- Use TreeFrog racks only in accordance with local motor vehicle and traffic regulations.
- Install rack and load luggage only at a safe distance away from moving traffic.
- Always remove the rack when not in use, and properly store it with its protective cover.

RESPONSIBILITY

- You must check all the TreeFrog vacuum pumps' white safety indicator bands on the rack before entering your car to start your journey.
- During your journey, check white indicator bands visually when you stop at gas stations or any resting places.
- The vacuum pumps' white safety bands will indicate if the vacuum cups are not maintaining vacuum, and will extend out and become visible upon loss of vacuum.
- If you see the pump's white safety indicator band, the vacuum level must be adjusted so that the white safety indicator is not visible before continuing on your journey.

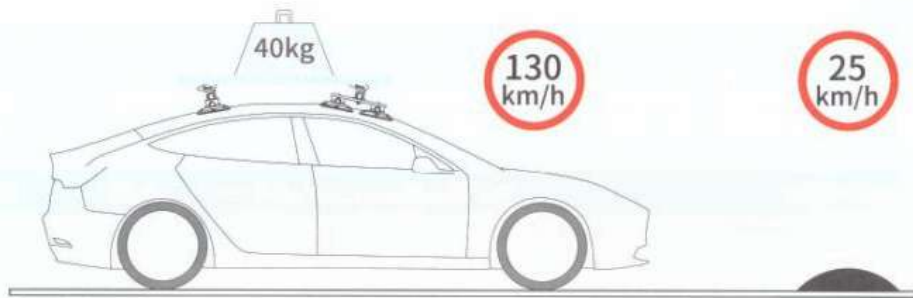

ASSEMBLY

- The TreeFrog Crossbar Racks need minor assembly prior to use.
- The crossbar with 2-2 vacuum mounts should be mounted at the front of the roof and the crossbar with 1-1 vacuum mount at the back.
- Place the vacuum cups close to the edge of the roof to have maximum internal support.
- Tighten the bolts between the crossbar and the vacuum mounts with the 4 hex key.
- After you secured the TreeFrog vacuum mounts with the hinges to the bars, the TreeFrog vacuum mounts are allow to move to accommodate the curve of your roof.
- Check both crossbars when you placed all the TreeFrog vacuum mounts at the first time, and make sure the crossbar carriers not move when pressure is applied.

Multiple Crossbar Racks | MXR0001S (B)

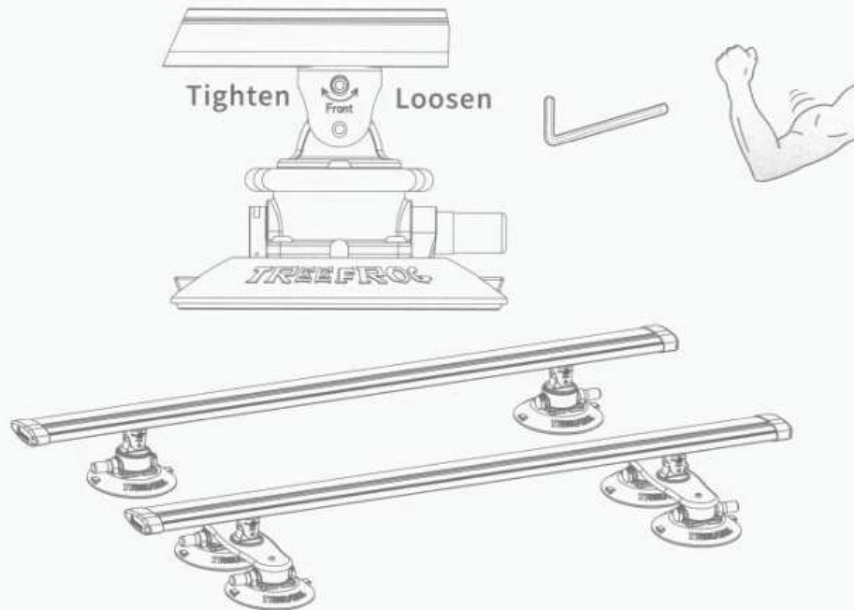

3

Multiple Roundbar Racks | MXR0001F

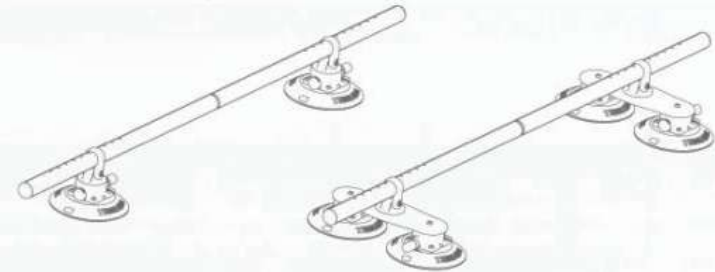
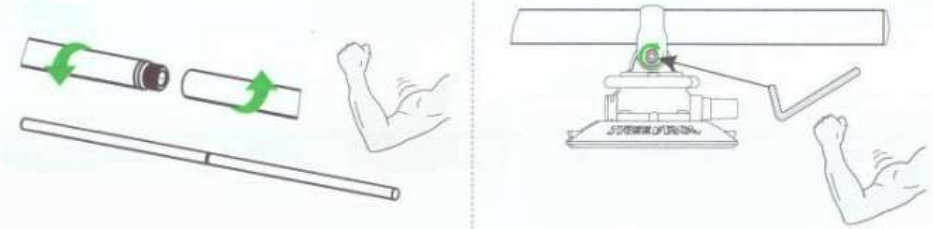

What's in the box:

Multiple Crossbar Racks MXR0001S (B)



Multiple Roundbar Racks MXR0001F

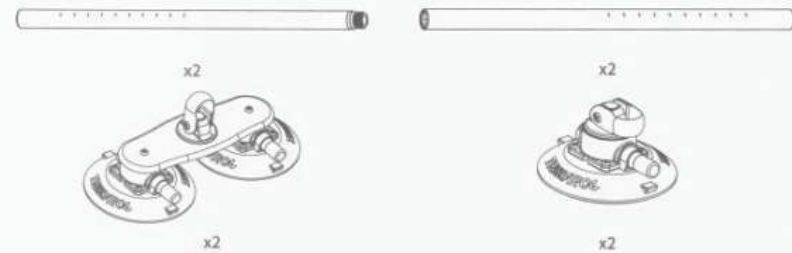

4

MOUNTING TREEFROG RACK

- Clean the surface where the rack's vacuum cup will be mounted with the TreeFrog soft rag that came with the rack. Then, remove the protective cover, and moisten the bottom edge of the cups with water only before you mount the rack. Next press the vacuum down to make sure the edge of the cup is connected and start pumping the air out until the white safety indicator band is no longer visible. Continue this process until all vacuum cups are secure.
- Always position the vacuum mounts close to the front edge of the roof, or to the front or back windshield and close to the side of the roof, where the roof has more internal support. Some cars' metal roofs may not be strong enough in the middle to support the box that are close to the weight limit.
- If the plunger will not stay seated and the pump's white safety indicator band becomes visible immediately after pumping, inspect the rubber vacuum pad for damage or clean the mounting surface and vacuum cup again. If the problem isn't solved after these basic steps, please do basic maintenance on the pump using the silicone lube that was supplied with the rack. **DO NOT** use your rack without solving the problem!
- Check the Crossbar Racks when you place it on the car roof and make sure it firm enough when pressure is applied.
- Attaching a rack to a sunroof is done at your own risk, and we strongly recommend that you test the strength and suitability of your sunroof first. **DO NOT** open the sunroof if any vacuum cup has been attached to the sunroof.
- All TreeFrog products can be used in rain, low temperatures and at high altitudes.

CAUTION:

- Never put water on the vacuum cups when the weather temperature could go below 0 Celsius!
- In low temperatures the rubber vacuum pads may become stiffer. When removing your rack, please store it at room temperature (or at least above 15 Celsius) before remounting it.
- During winter make sure the surface is dry and free of ice before mounting the rack!

How to pump

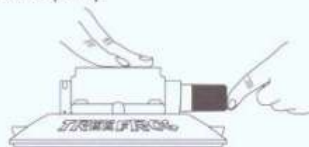

1. Press the vacuum down to make sure the edge of the cup is connected.
2. Pumping the air out until the white safety indicator band is no longer visible.

Full Power



Indicator band exposed: time to re-pump

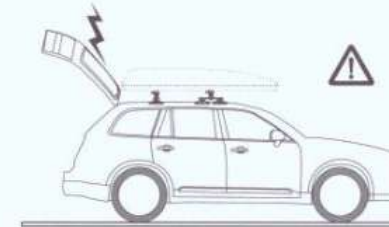
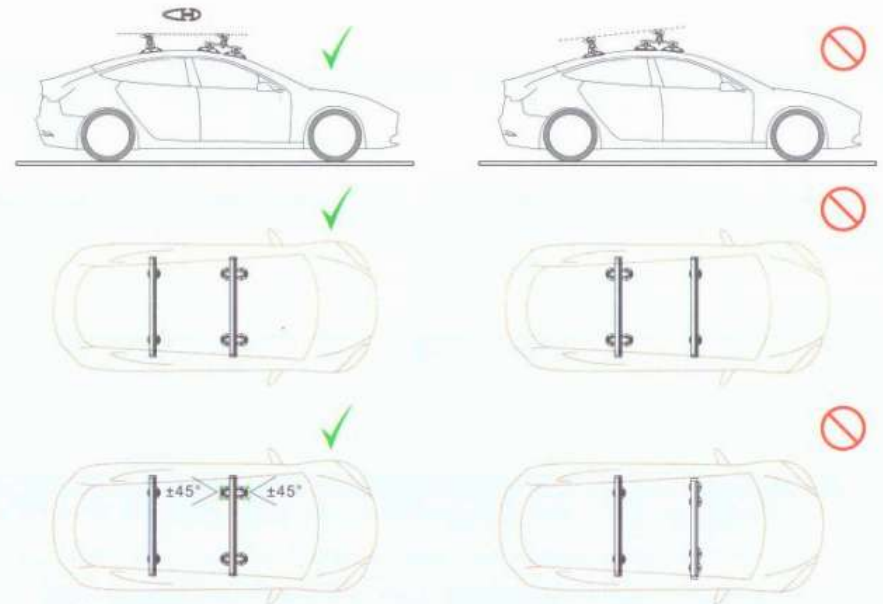

DEMOUNTING TREEFROG RACK

- Simply lift up the vacuum cup anywhere around its edge to break the vacuum seal.
- When you have removed all the vacuum cups, please put the protective cover back.

NOTE - Never place or store the rack on the rubber vacuum cups without protective covers!

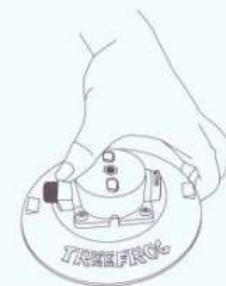

How to break the vacuum seal



Always put the protective cover back when not in use

REGULAR CHECKING AND PUMP MAINTENANCE

- Keep the vacuum cups clean, and always store them with the protective green covers. Please use the soft TreeFrog rag that came with the product and clean the vacuum pads with water before each use. If you observe any dirt on the vacuum pad, please remove it with soapy water and the soft TreeFrog rag.
- Please check all the screws and hardware regularly to make sure they haven't come loose during previous use. Tighten the housing to the vacuum pad, and the deck to the vacuum cup screws, and the box screws and bolts if necessary. Regardless of how many times the rack has been used, you must perform maintenance on the vacuum pumps if any of the pump's white safety bands appear less than 3 hours after the vacuum cup has been mounted and pumped to full strength. We also recommend, after the rack not being used for a long period of time, or before the cycling season starts, and you would like to use the rack regularly again, please test the rack on your car and check how long the vacuum pumps hold a seal before the white safety band appears. Before cycling season starts, that is the best time to perform maintenance and get your rack ready for the season!



Check to ensure there is no scratch on the edge of the vacuum cup.



Pull the plunger straight out from the pump cylinder.



Clean the inside of the cylinder and the plunger with a lightly wet paper towel



Re-lube the rubber O-ring with a thin layer of silicone gel



Push the plunger back into the cylinder and pump several times to ensure the pump move back and forth freely and smoothly



Always put the protective cover back when not in use

You must perform maintenance on the vacuum pumps if one of the pump's white safety bands appear less than 3 hours

- To perform maintenance on the pump, simply grab the pump's white indicator and pull the plunger straight out from the cylinder. Clean the cylinder inside with a lightly wet paper towel. After you have cleaned the cylinder inside, please wipe it with a dry paper towel. Next, clean the head of the plunger and the rubber O-ring. You must re-lube the rubber O-ring with a thin layer of silicone gel that came with the rack, and push the plunger back to the cylinder. After you have finished these maintenance steps, the pump should move back and forth freely and smoothly. Please test all the rack's vacuum cups by placing them on your car or any glass surface for the next 20-24 hours. If the white safety band does not appear, you can start to use your rack. If the white safety band appears, please repeat the maintenance steps until the pump performs well.

NOTE - Any damaged hardware, pumps or vacuum pads must be replaced. All replacement parts are available at www.treefrogtracks.com

- We recommend to return the rack to your local dealer, so they can perform the maintenance for you.

-We are also offering free maintenance to all TreeFrog customers. Simply ship the product back to our service center and we charge only for the necessary replacement parts.

To take advantage of this free maintenance option, please email us at iinfo@treefrogtracks.com

Tutor maintenance videos also available at www.treefrogtracks.com

GUARANTEE

The Guarantee covers any defect or damage affecting your TreeFrog product for 2 years following the date of the purchase of the first customer. Guarantee gives you specific legal rights. It does not affect any statutory rights that you have as a customer of a defective product. Guarantee does not cover defects resulting from conditions beyond TreeFrog's control. Including but not limited to misuse, overloading or failure to assemble, mount or use the product or it's accessories in accordance with the TreeFrog's written instructions, guidelines and safety specifications. Nor does it cover any damage to the user's vehicle, electronic devices, cargo, or to any other person or property.

TREEFROG DISTRIBUTORS RESERVES THE RIGHT TO:

- Repair the item falling under the terms of the guarantee
- Replace the item if the damage or defect cannot be repaired
- Offer a similar product of comparable value, or refund the price paid, if the original product can not be replaced with the same model

WARRANTY

The TreeFrog warranty applies to products and accessories produced by TreeFrog and sold to the original customer under the brand name TreeFrog. The warranty covers defects in materials or workmanship and, depending on the type of product, applies up to 2 years from the date of the original retail purchase. Subject to the limitations and exclusions described in this warranty, TreeFrog remedies defects in materials or workmanship during the warranty period by repairing or replacing the defective component(s) without charge for parts or labour.

Accessories and other products please find at: www.treefrogtracks.com or contact the local dealers.



TREEFROG Sports Equipment Co., Ltd.

 www.treefrogracks.com

 info@treefrogracks.com